

FRANKLIN WIRELESS

Add a sophisticated touch to your facility. Brushed aluminum clocks offer an upscale, high tech look that will enhance any décor.

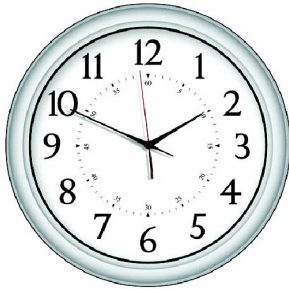

13" Brushed Aluminum
- Battery -
Part # 510016

SEE PART NUMBER
DATA SHEET FOR ALL OPTIONS
AVAILABLE

Features:

- Brushed Aluminum Cases
- Glass Lens
- Sophisticated Metallic Appearance
- Battery (2 D-Cell) or Electric 120/24 VAC
- Maintenance Free

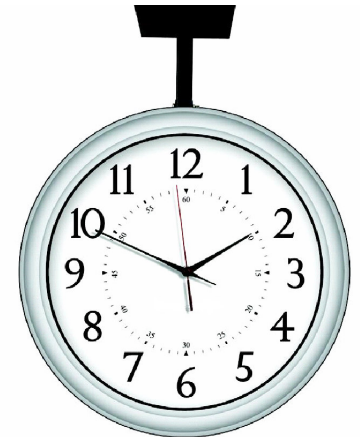

16" Double Sided Ceiling Mount
- Battery -
Part # 520016

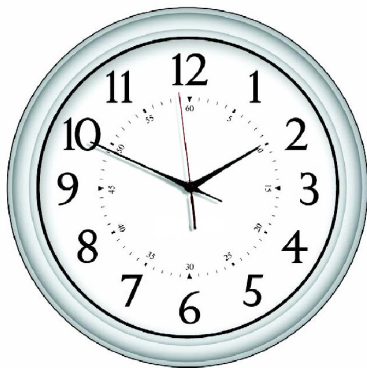

16" Brushed Aluminum
- Battery -
Part # 510006

DIAL OPTIONS

Additional Custom Logo Designs Available

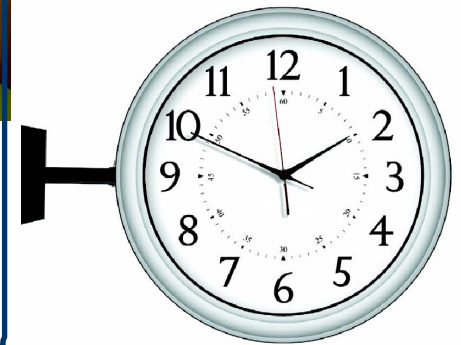

16" Double Sided Wall Mount
- Battery -
Part # 520026



Standard Arabic 12/60 Part # SA60

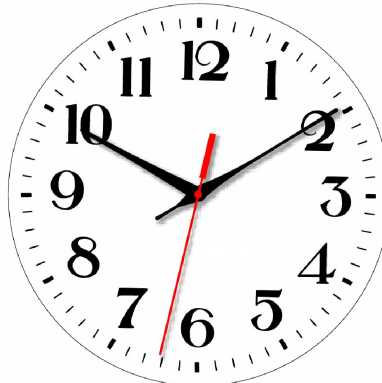

Classic Arabic Part # CA00

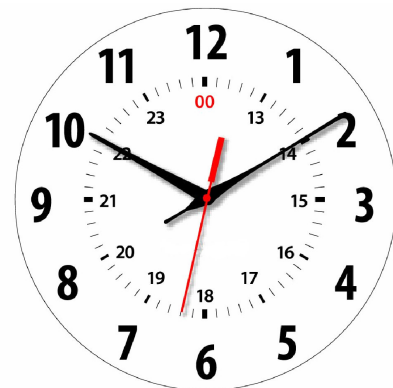

Standard Arabic 12/24 Part # AS24

13" Brushed Metal Clock

Specifications

- Brushed Aluminum Cases
- Glass Lens
- Sophisticated Metallic Appearance
- Battery (2 D-Cell) or Electric 120/24 VAC
- Maintenance Free

Rear Case Diameter: 13.125"

Front Case Diameter: 13.0"

Dial Graphics Diameter: 9.75"

Edge Thickness: 2.5"

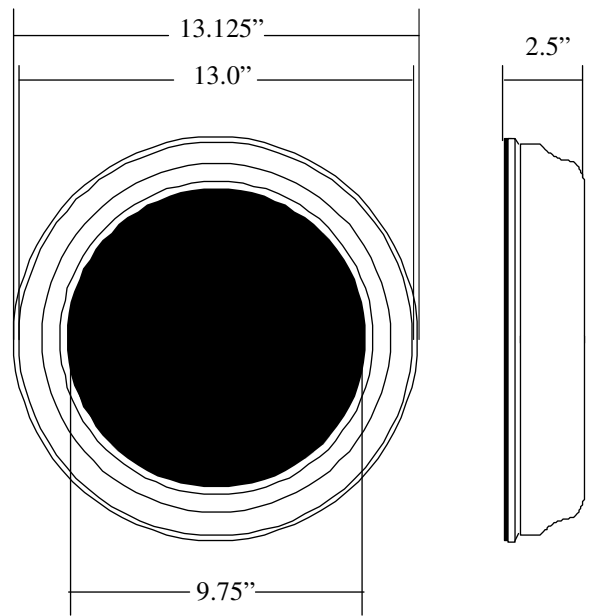

16" Brushed Metal Clock

Specifications

- Brushed Aluminum Cases
- Glass Lens
- Sophisticated Metallic Appearance
- Battery (2 D-Cell) or Electric 120/24 VAC
- Maintenance Free

Rear Case Diameter: 16.0"

Front Case Diameter: 15.75"

Dial Graphics Diameter: 12.25"

Edge Thickness: 2.75"

Ceiling and Side Mount Dimensions: 3"H x 4.5"D

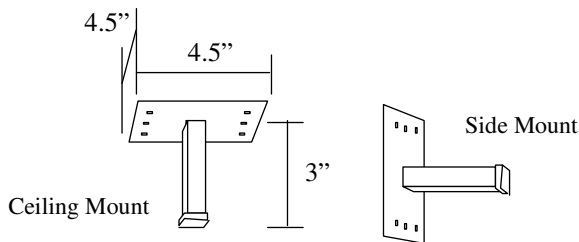
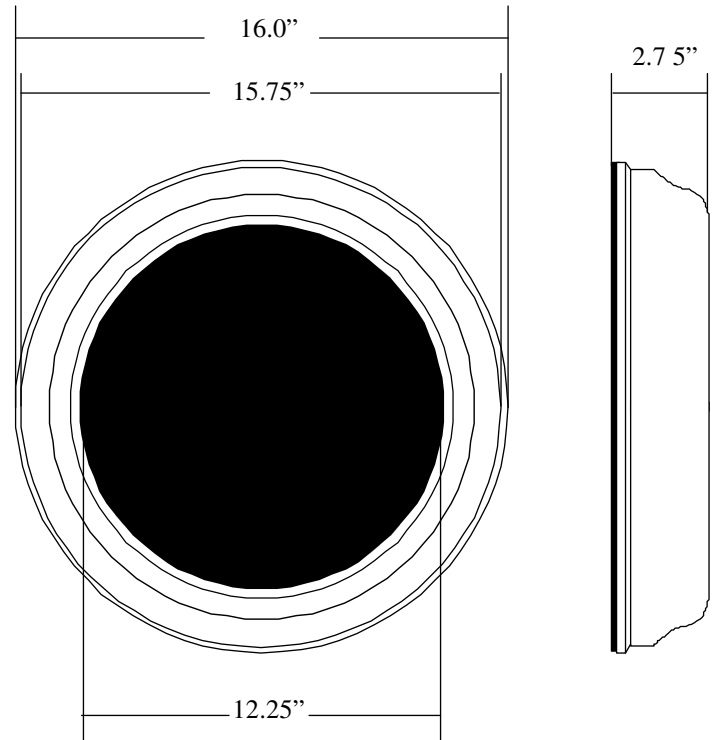

13" and 16" Rear View

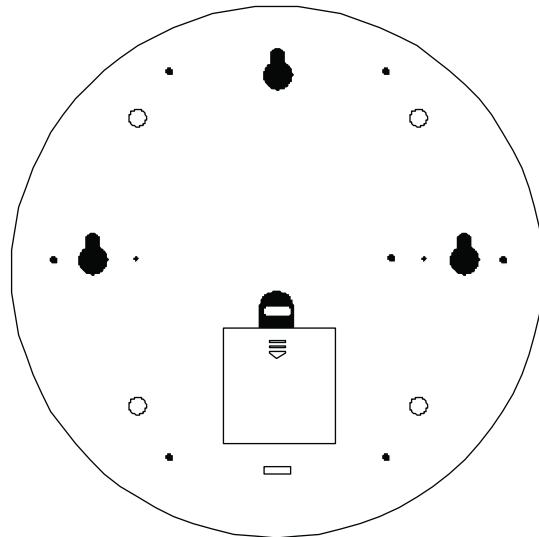

Franklin Instrument Company

233 Railroad Drive

Warminster Pa 18974

Phone (215)-355-7942 or (800)-321-2353

Fax (215)-322-1022

www.franklinclock.com